

---

**ABSTRACT**

Reflection coefficient, transmission coefficient and orientation diagram of  $\pi$ -sector transition antenna from rectangular waveguide to the megaphone are defined as experimental.  $\pi$  type is determined as the main type in rectangular waveguide transmitting electromagnetic waves. The main parameters of the rectangular waveguide measuring are calculated by methods of Galerkin and Rits. Theoretical and experimental results have been compared and the error between them have been determined as satisfactory.

**KEYWORDS:** reflection coefficient, transmission coefficient, orientation diagram, rectangular waveguide, electromagnetic waves, megaphone.

---

**INTRODUCTION**

Characteristics of the antenna system, also from rectangular waveguide to the megaphone need to improve for increasing information density transmitting radio channels. We can add reflection coefficient  $Q$ , transmission coefficient  $P$  and orientation diagram to the characteristics from rectangular waveguide to the megaphone. Thus, the transmission rate  $P$  determines orientation diagram and the form of side petals and its width. The reflection coefficient  $Q$ , determines the characteristic of the propagation regime of electromagnetic wave transmitting to antenna device from transceiver device [1-8].

We have to ensure escaping wave in the antenna-feeder tract to achieve antenna in maximum power transmitting transceiver device in the real practice. Therefore the obligation of issue of reducing of reflection coefficient  $Q$ , along tract appears. At the same time, number of side petals of orientation diagram must be minimum to create microwave communication in transmitter-receiver system for equal propagation of parabolic antenna. This, in turn, is achieved at the expense of reducing of the transmission coefficient  $P$  and alignment of front phase of electromagnetic wave [9-16].

As we see, at the same time the fulfillment of these conditions are complicated issue [17-20]. Therefore, the minimizing of reflection coefficient  $Q$  and transmission coefficient  $P$  can be carried out by methods of Galerkin and Rits. Transition from rectangular waveguide to the megaphone is investigated emitting microwave electromagnetic waves in this publication in order to minimize reflection coefficient  $Q$  and transmission coefficient  $P$ .

**EXPERIMENTAL STUDY**

In figure 1 space model of rectangular waveguide working in wave  $H_{10}$ , but in figure 2 the consolidation scheme to megaphone is shown. This rectangular waveguide works in frequency range  $4,9 \div 7,05GHz$ . Its cross-sectional

dimensions are  $40 \times 20 \text{ mm}$  and made of brass. Geometric length of microwave rectangular waveguide is  $L = 105 \text{ mm}$ .



Figure 1. Space model of rectangular waveguide working in wave  $H_{10}$ .

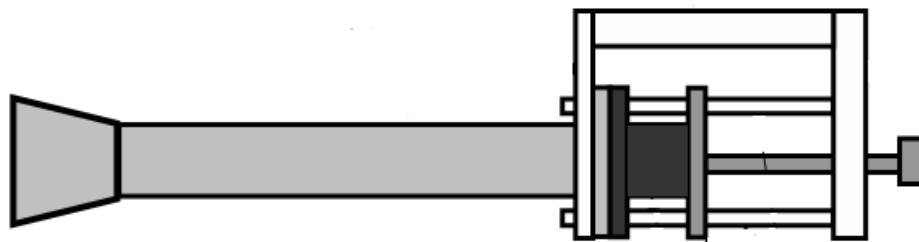

Figure 2. Consolidation scheme to megaphone of rectangular waveguide working in wave  $H_{10}$ .

Experimental study of characteristics of microwave devices transition from rectangular waveguide to the megaphone is associated with determination of the orientation diagram and stagnant wave coefficient  $Q_{dd}$ . The study has been carried out the price  $\lambda = 3 \text{ cm}$  of wavelength and measurements have been fulfilled with waveguide measure line. The measurement of orientation diagram has been carried out with the help of laboratory complex. Block-diagram of device determining stagnant wave coefficient  $Q_{dd}$  has been shown in figure 3.

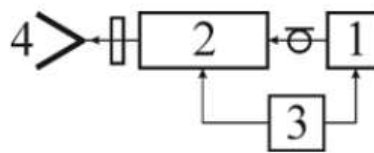

Figure 3. Block-diagram of device determining stagnant wave coefficient  $Q_{dd}$ :

1-FC-11-type microwave signal generator; 2- P1–28 type waveguide measuring line; 3-power supply; 4- megaphone radiation.

The measurement of following parameters has been carried out:

- stagnant wave coefficient in microwave rectangular waveguide working in type wave;
- orientation diagram.

Reflection coefficient is determined with the following formula:

$$Q = \frac{Q_{dd} - 1}{Q_{dd} + 1}. \quad (1)$$

Measurements have been carried out with the following methods. Megaphone radiation has been fixed to the output of measuring line of P1–28 type waveguide. Input of P1–28 type measuring line from generator is provided with  $\lambda = 3\text{cm}$  length microwave signal. Millivoltmeter is connected to a measuring line via Hann diode.  $\alpha_{\max}$  – maximum and  $\alpha_{\min}$  – minimum prices are determined with the help of this millivoltmeter. Then, according to the following formula stagnant wave coefficient  $Q_{dd}$  is set for the voltage:

$$Q_{dd} = \sqrt{\frac{\alpha_{\max}}{\alpha_{\min}}}. \quad (2)$$

Then, according to formula (1), reflection coefficient  $Q$  is set. The experimental determination of orientation diagram has been carried out with the help of specially designed laboratory facility which the sizes are  $4 \times 6\text{m}$  in a closed room condition. Structural scheme of the measurement device in figure 4, a space model is shown in figure 5.

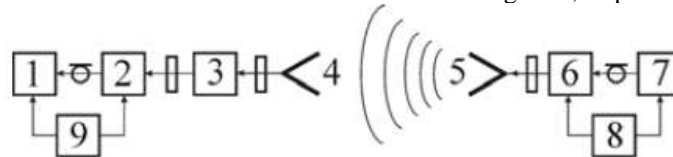
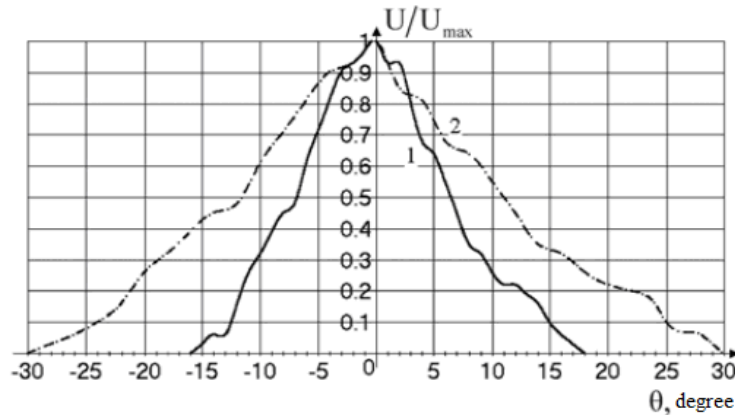

**Figure 4. Block diagram of the experimental determination of orientation diagram:**  
1-indicator device; 2-receiver block; 3-adjustable attenuator; 4- receiver megaphone; 5- transmitter megaphone; 6-generator block; 7-modulated block; 8, 9-power supply.



**Figure 5. Space model of the experimental determination of orientation diagram.**

Measurement was carried out with the following methods. Microwave klystron generator 6 has been connected to the body together megaphone radiation 5. Receiver megaphone has been built at least 3 meters away (remote zone) from the transmitter. The transmitter and receiver megaphones have been built along an axis. Signal is given to millivoltmeter device of indicator block from the outlet of receiver megaphone.  $U(mV)$  voltage is measured in output of the receiver device by changing the angle  $\theta$   $1^\circ$  discrete at the vertical plane. Then according to the intensity and strength of the field, normalized orientation diagrams are. The width of orientation diagram are determined with levels 0,707 and 0,5 of intensity and power by graphical method. According to the intensity of electromagnetic field, normalized orientation diagrams have been shown via curve 1 in figure 6.



**Figure 6.** According to the intensity of field, orientation diagram of megaphone radiation:  
1-orientation diagram at the vertical plane; 2-orientation diagram at the horizontal plane.

Measurements have been carried out in relation to the axis of megaphone device at interval from  $-90^0$  to  $+90^0$  of  $\theta$ .

The schemes for the measurement of transmission and reflection coefficients modules in figure 7 and figure 8, the curves obtained from the computer these parameters are shown in figure 9.

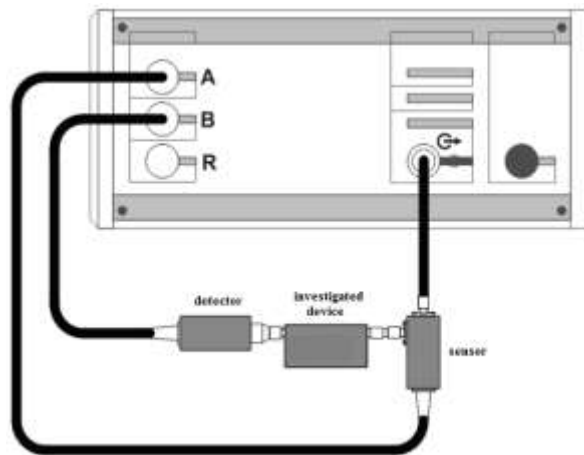

**Figure 7.** Scheme of measurement of transmission and reflection coefficients modules.

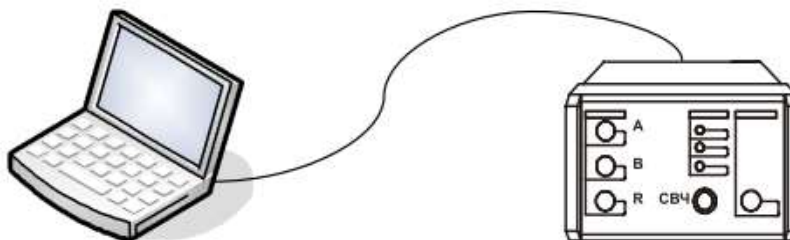

**Figure 8.** Connection of scheme of measurement of transmission and reflection coefficients modules to the computer.

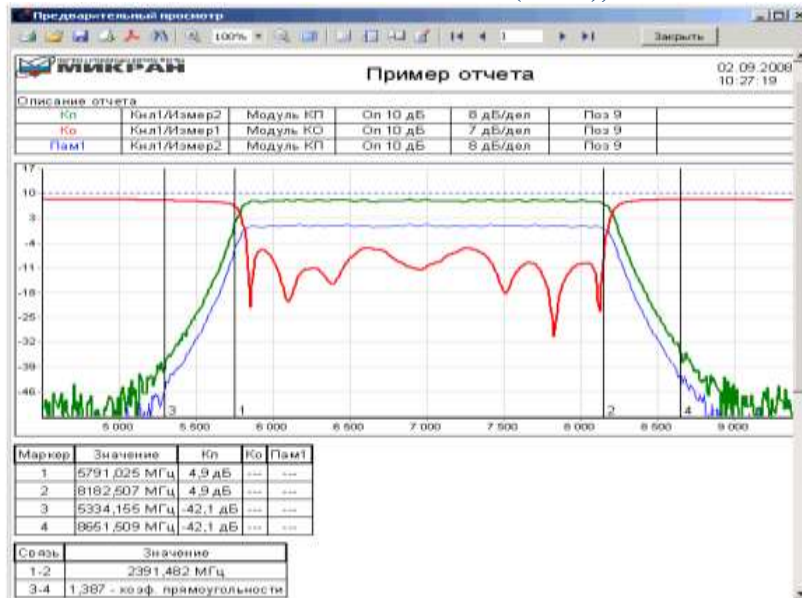

Figure 9. Results of modules of transmission and reflection coefficients obtained from computer.

## RESULTS AND DISCUSSION

According to the wavelength of  $\lambda = 3\text{cm}$ , standing wave ratio is  $Q_{dd} = 1,42$ , reflection coefficient is  $Q = 0,17$ . Standing wave ratio of investigated megaphone radiation is  $Q_{dd}=1,96$ , but the reflection coefficient is  $Q = 0,32$ . The price of standing wave ratio  $Q_{dd}$  of megaphone radiation is so great that his performance is due to the geometric dimensions. For this reason, smoothing of this part of megaphone has been fulfilled and following results have been obtained for standing wave ratio  $Q_{dd} = 1,32$ ,  $Q = 0,14$ . According to the intensity of electromagnetic field, width of orientation diagram of megaphone radiation is  $2\theta = 8,8^{\circ}$  at the level of 0,707.

## CONCLUSION

As a result of study of the megaphone radiation, reflection coefficient  $Q$  and transmission coefficient  $P$  have been significantly improved. It also reduced the size of investigated rectangular waveguide and geometrical dimensions of megaphone devices. Investigated megaphone radiations can be used in ship's antenna complexes, as well as aviation and astronautics, radiolocation, radionavigation, television systems. Minimizing of reflection coefficient  $Q$  and transmission coefficient  $P$  is a new scientific result. The practical importance of the article is correlated with being created of broadband mirror parabolic antenna which manage orientation diagram and performance coefficient.

## REFERENCES

- [1] I.J.Islamov. Transaction of Azerbaijan Academy of Sciences, Series of Physical-mathematical and Technical sciences, Physics and Astronomy, XXIV №2 (2004) 48-57.
- [2] I.J.Islamov. Transaction of Azerbaijan Academy of Sciences, Series of Physical-mathematical and Technical sciences, Physics and Astronomy, XXIII №2 (2003) 205-214.
- [3] E.G.Ismibayli, I.J.Islamov, Y.G.Gaziyeu. Calculation Of The Electromagnetic Field Of The Microwave Of Devices With Use Of Method FDTD And Integral Kirchhoff. International Journal of Engineering Innovation and Research (IJEIR), Volume 5, Issue 1, (2016) 103-106.

- [4] E.G.Ismibayli, I.J.Islamov, Y.G.Gaziyev. Modeling Of Electromagnetic Fields Of Microwave Devices On The Basis Of Matlab Program. *International Journal of Innovative Science, Engineering and Technology (IJSET)*, Volume 3, Issue 2, (2016) 61-63.
- [5] E.G.Ismibayli, I.J.Islamov, Y.G.Gaziyev. An Optimal Control Of An Electromagnetic Field In High-Powered Microwave Devices. *International Journal of Trend in Research and Development (IJTRD)*, Volume 3(1), (2016) 246-249.
- [6] E.G.Ismibayli, I.J.Islamov, Y.G.Gaziyev. Modeling of Anisotropic Rectangular Waveguide Partially Embedded in an Anisotropic Substrate. *Journal of Multidisciplinary Engineering Science and Technology (JMEST)*. Volume 2, Issue 2, (2015) 153-157.
- [7] Islam J. Islamov. Application of finite elements method by calculating electric field of hollow rectangular waveguide. *IASTED-2005*, Canada, Calgary, (2005) 26-32.
- [8] Islam J. Islamov. Numerical method for analysis of electromagnetic field of microwave waveguide. *International Conference on Antenna Theory and Techniques*. September 9-12, Sevastopol, Ukraine, (2003) 45-50.
- [9] E.G. Ismibeyli, I.D. Islamov. The Analysis of Magnetic Devices In Frequency Directors of Teledynamometring Systems. *The Third International Scientific Practical Conference "Khazarneftgasyatag-98"*, November, Baku, (1998) 10-13.
- [10] De Moerloose Jan, Dawson Trevor W., Stuchly Maria A. Application of the finite difference time domain algorithm to quasi-static field analysis. *Radio Sci.*-32, №2 (1997) 329-341.
- [11] M.Koshiba, M.Okada, M.Suzuki. Numerical analysis of two-dimensional piezoelectric waveguides for surface acoustic waves by finite-element method. "Electron. Lett.", №17 (1981) 609-611.
- [12] Y.E.Elmoazzen, Shafai Lotfollah. Numerical solution of coupling between two collinear parallel-plate waveguides. *IEEE Trans. Microwave Theory and Techn.*, 23(11), (1975) 871-876.
- [13] T.P.Barton. Electromagnetic field calculations for irregularly shaped, layered cylindrical particles with focused illumination. *Appl.Opt.*, 36, (1997) 1312-1319.
- [14] V.Iomota, P.Alotto. Magnetic field computation in media with hysteresis. *Rev. roum. sci. techn. Ser. Electrotechn. et energ.* 41(3), (1996) 291-296.
- [15] K. Dikshitulu Kalluri. *Elektromagnetik Waves. Materials and computation with Matlab. CRS Press London-New York*, (2012) 835.
- [16] N.O.Matthew Sadiku. *Numerical Techniques in Electromagnetic with Matlab. CRS Press London-New York*, (2012) 707.
- [17] Munteanu Irina. A method for numerically solving Maxwell's equations in three dimension. *Politehn. Univ. Bucharest*. 56(1-4), (1994) 221- 238.
- [18] Miller Edmund K., Burke Gerald J. Low frequency computational electromagnetics for antenna analysis. *Proc. IEEE*. 80(1), (1992) 24-43.
- [19] Chen Bao Xue, Hamanaka Hiromi, Iwamura Kokya. *J. Opt. Soc. Amer.* 9(8), (1992) 1301-1305.
- [20] H.Cory, A.Novick-Cohen, D.Levy. Variational expression for propagation along a closed rectangular chiro waveguide. *Antennas and Propag.*, 143(2), (1996) 174-178.